

# Free Standing Enclosures

## Type 12 Two Door & Two Door Dual Access



**APPLICATIONS** - Provide protection for electrical terminals, controls, and instruments from dirt, dust, dripping liquids, and oil. Free standing enclosures are designed to accept Unistrut® mounted sub-panels, rack angles or other adjustable mount equipment.

**CONSTRUCTION** - Fabricated from 10 and 12 gauge carbon steel, type 304 or 12 gauge type 316 stainless steel with continuously welded seams. Enclosure features:

- Doors are secured with heavy-duty continuous hinges with removable hinge pins and key locking handle with three point latching system
- Adhesive backed, oil resistant gasket applied to the doors
- Unistrut channel
- Print pocket
- Heavy-duty lifting bolts
- Ground studs inside cabinet and door
- Body stiffeners for extra rigidity where needed (not applicable for dual access)
- Collar studs provided for mounting optional sub panel in back.

**ACCESSORIES (Ordered Separately)**

- Sub-panels include full size, half-size, side mount, and swing-out panels. Sub-panels can be mounted and adjusted for depth on the horizontal unistrut channel

- Clamping nuts for installing other equipment
- Center panel supports

**FINISH** - Standard RAL 7035 texture polyester powder coat finish on interior and exterior of enclosures. Recoatable, smooth, white or ANSI-61 gray available at no charge. Standard RAL and custom match finishes available for an additional charge, please contact Schaefer's Electrical Enclosures, Inc. for further assistance. All powder coat finishes applied over cleaned phosphatized surfaces. Carbon steel sub panels have a white polyester powder coat finish. Stainless Steel enclosures have a polished #4 finish.

**OPTIONS** - Schaefer's Electrical Enclosures, Inc. can modify standard enclosures or custom design enclosures according to your specifications. Holes, cutouts, sizes, materials, and many more options are available. Quotations upon request.

**INDUSTRY STANDARDS**

- UL 50 Listed
- CUL 50 Listed
- Type 12

Catalog Number			Enclosure Size H x W x D (inches)	Shpg. Wt.	Sub Panel Part # (Full Panel)	Sub Panel Size H x W (inches)	Sub Panel Part # (Half Panel)	Sub Panel Size H x W (inches)	Side Mounted Panel Part #	Side Panel H x W (inches)	Lift. Eyes
Carbon Steel #	304 Stainless Steel #	316 Stainless Steel #									
Two Door - Single Access											
SPFSD-604818	SPFSDSS-604818	SPFSDSS6-604818	60 x 48 x 18	430	SP-60P48F2	48 x 44	SP-60P48F2	24.88 x 44	SP-60SMP14	48 x 14	2
SPFSD-724818	SPFSDSS-724818	SPFSDSS6-724818	72 x 48 x 18	492	SP-72P48F2	60 x 44	SP-72P48F2	30.88 x 44	SP-72SMP14	60 x 14	2
SPFSD-726018	SPFSDSS-726018	SPFSDSS6-726018	72 x 60 x 18	568	SP-72P60F2	60 x 56	SP-72P60F2	30.88 x 56	SP-72SMP14	60 x 14	2
SPFSD-727218	SPFSDSS-727218	SPFSDSS6-727218	72 x 72 x 18	645	SP-72P72F2	60 x 68	SP-72P72F2	30.88 x 32	SP-72SMP14	60 x 14	2
SPFSD-904820	SPFSDSS-904820	SPFSDSS6-904820	90 x 48 x 20	590	SP-90P48F2	78 x 44	SP-90P48F2	39.88 x 44	SP-90SMP16	78 x 16	2
SPFSD-907220	SPFSDSS-907220	SPFSDSS6-907220	90 x 72 x 20	783	SP-90P72F2	78 x 68	SP-90P72F2	39.88 x 68	SP-90SMP16	78 x 16	2
SPFSD-724824	SPFSDSS-724824	SPFSDSS6-724824	72 x 48 x 24	530	SP-72P48F2	60 x 44	SP-72P48F2	30.88 x 44	SP-72SMP20	68 x 20	4
SPFSD-726024	SPFSDSS-726024	SPFSDSS6-726024	72 x 60 x 24	645	SP-72P24F2	60 x 20	SP-72P24F2	30.88 x 20	SP-72SMP20	60 x 20	4
SPFSD-727224	SPFSDSS-727224	SPFSDSS6-727224	72 x 72 x 24	694	SP-72P72F2	60 x 68	SP-72P72F2	30.88 x 68	SP-72SMP20	60 x 20	4
SPFSD-907224	SPFSDSS-907224	SPFSDSS6-907224	90 x 72 x 24	825	SP-90P72F2	78 x 68	SP-90P72F2	39.88 x 68	SP-90SMP20	78 x 20	4
SPFSD-726036	SPFSDSS-726036	SPFSDSS6-726036	72 x 60 x 36	750	SP-72P60F2	60 x 56	SP-72P60F2	30.88 x 56	SP-72SMP32	60 x 32	4
SPFSD-907236	SPFSDSS-907236	SPFSDSS6-907236	90 x 72 x 36	1000	SP-90P72F2	78 x 68	SP-90P72F2	39.88 x 68	SP-90SMP32	78 x 32	4

**NOTE:** Full, half, and side sub panels must be ordered separately. Reference page 124 & 125 for sub panel layout



Catalog Number			Enclosure Size H x W x D (inches)	Shpg. Wt.	Sub Panel Part # (Full Panel)	Sub Panel Size H x W (inches)	Lifting Eyes
Carbon Steel #	304 Stainless Steel #	316 Stainless Steel #					
Two Door - Dual Access							
SPFSDAD-724824	SPFSDADSS-724824	SPFSDADSS6-724824	72 x 48 x 24	595	SP-72P48F2	60 x 44	4
SPFSDAD-726024	SPFSDADSS-726024	SPFSDADSS6-726024	72 x 60 x 24	615	SP-72P60F2	60 x 56	4
SPFSDAD-727224	SPFSDADSS-727224	SPFSDADSS6-727224	72 x 72 x 24	695	SP-72P72F2	60 x 68	4
SPFSDAD-907224	SPFSDADSS-907224	SPFSDADSS6-907224	90 x 72 x 24	825	SP-90P72F2	78 x 68	4
SPFSDAD-726036	SPFSDADSS-726036	SPFSDADSS6-726036	72 x 60 x 36	750	SP-72P60F2	60 x 56	4

**NOTE:** Full, half, and side sub panels must be ordered separately. Reference page 124 & 125 for sub panel layout

**SPFSD Two Door**

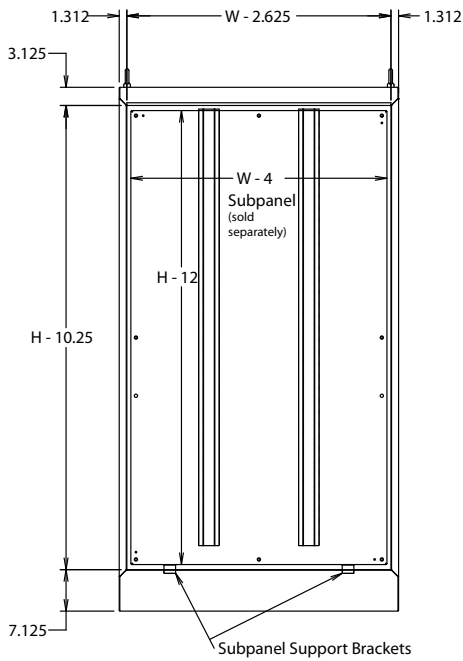

Doors Removed

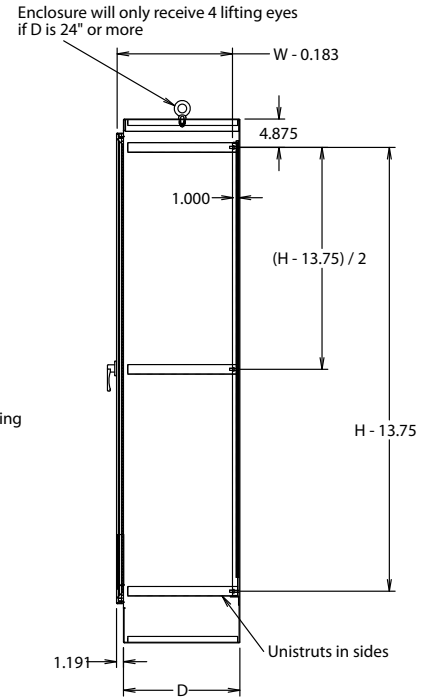
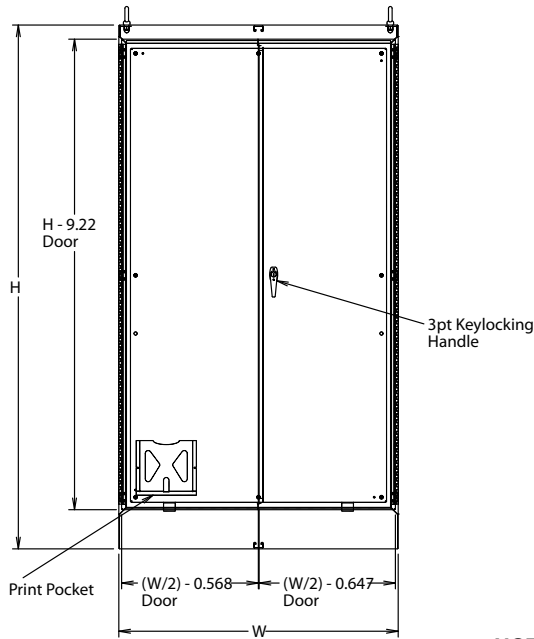

**NOTES:**

1. 9" x 9" Print pocket shipped inside enclosure.

**SPFSDAD Two Door Dual Access**

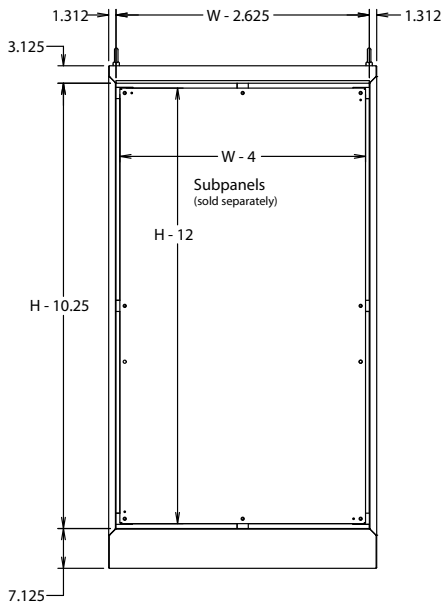

Doors Removed

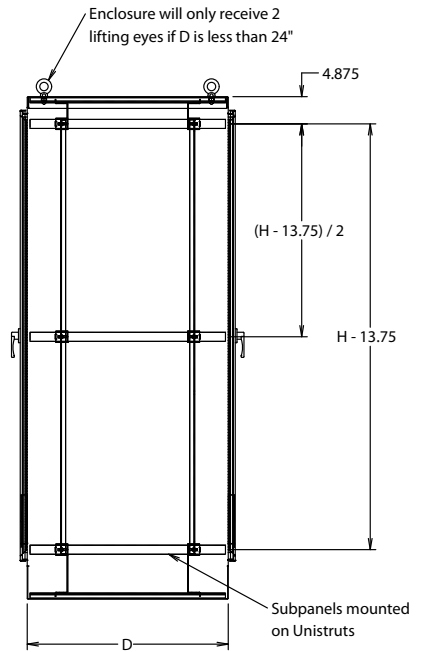
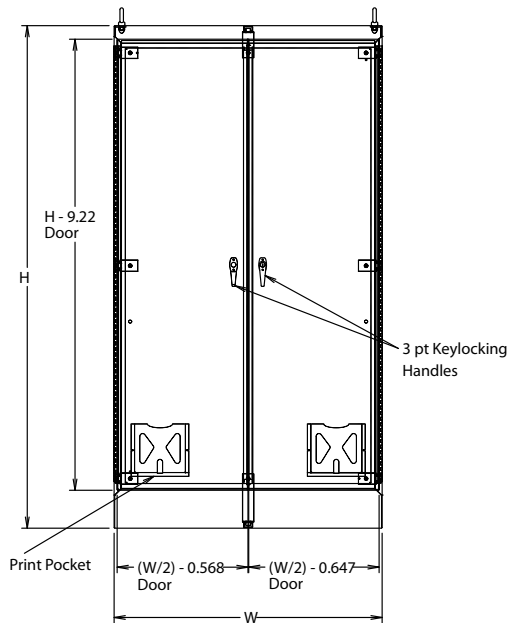

**NOTES:**

1. 9" x 9" Print pocket shipped inside enclosure.